

# WOODFOLD INSTALLATION INSTRUCTIONS: SERIES 240, 440, 540, 640 & 740



Read and understand these instructions before proceeding.  
It saves frustration!

Examine the installation site before proceeding. Beginning installation before checking things out is discouraged.  
**Measure Twice - Cut Once** so to speak

## 1 Preparation

### Preliminary Examination

Confirm the match of the packaged door to the intended opening. The sample label to the right shows the location of the critical information.



Inspect the packaging. If the package was damaged when it arrived, contact the shipping carrier first, then notify Woodfold.

Lay out the contents on a flat surface near the opening where the door is to be installed.

Opening Width: 3-8  
Right/Left Hand Single/Double End: RH  
Opening Height: 6-6.25  
Door Material: Mahog  
Bronze Hdwr  
Keylock Room Div  
Brown Geon 0.5625" Fl. Cl.  
RH SE BB Whls  
Door Series: 240V  
Reg Bronze Trk  
Block Height 5  
Block Width 7.5  
Crdb:rd Width 15  
Cbrd Length 80.312  
1 @ 44  
05-08-0968  
2005-09-12  
Number of Track Pieces and Length  
Order Number

The package(s) contents should include

- ✓ Door(s)
- ✓ Track Section(s)
- ✓ Interlocking Jamb Molding (See box at right)
- ✓ Hardware packet (screws, spring pins if multiple sections of track)
- ✓ These instructions (Yes, yes, we know you had to find them if you're reading them, but we like to be complete.)
- ✓ A copy of the shipping label with all the information you need if you have to call Woodfold for any reason. Hold on to it for future reference.

### Doors Without Key Locks



### Doors With Key Locks

### And NOW, a short word about Interlocking Jamb Molding

The Interlocking Jamb Molding is the extruded piece into which the door latches. If your door slides from each end to meet in the middle, your Interlocking Jamb Molding are already installed on a lead post of the door and you may disregard that section of the Instructions on page 4. Configurations where the door closes to a wall or doorjamb will have a separate piece with a cross section like one of those shown on the left.



**Power Screw Drivers:** Check the length of your #2 Phillips Bit. It needs to extend at least 1 1/4" past the chuck. Any shorter and the chuck may tear up the track or the screw won't seat. It falls into the frustrating category when you have to ask Woodfold for a new track.



**Caution!** The factory greased the track for smooth operation! Hands and tools can spread the grease all over, so please be careful.

Dry fit the track in the opening. The correct length will just fit into the opening. If needed, trim the track with a hacksaw. Try to keep the metal filings from mixing with grease inside the track.

If the track is too short by more than 1/2" contact Woodfold for a replacement track.

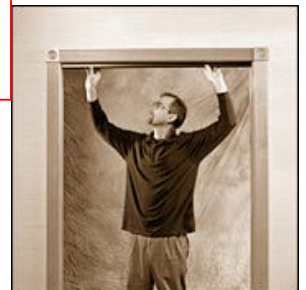

## Even and Odd Door Panels

The factory puts in enough door panels to fill the opening. That seems obvious but it means some doors have an even number of panels and others an odd number. The consequence is that the mounting panel on your door may point in the other direction than those shown in illustrations.

# DON'T PANIC! IT'S OK!

The factory just had to use a different number of panels than used in the illustration.

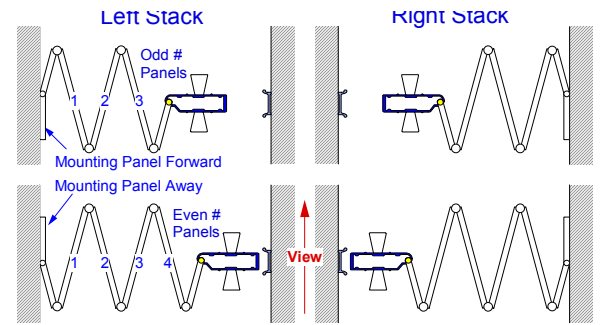

**The next few steps are much easier if you have assistance.**

## 2 Track Installation (see addendum for bendable I-Beam track)

There are different installation techniques for single section or multi section tracks. If you have multi section track, jump to ***If the track is in two or more pieces*** section below.



**Caution! Firmly attach the track to the structural header! Sheetrock and many decorative materials do not provide adequate support.**

### ***If the track is in one piece***

Thread the track onto wheels; lineup the wheels properly in the track grooves. Be careful not to insert the wheels sideways. You won't like the result.

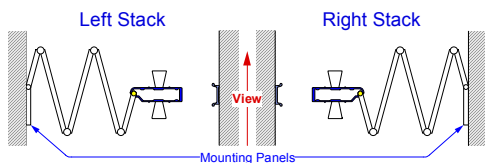

Confirm the proper orientation of the door. See the illustrations of Left or Right Stack doors to the left or Double Ended doors on the following page. Position the track to ensure: a) it can be securely attached to the header and b) the Mounting Panel can be securely attached to the wall or doorjamb.

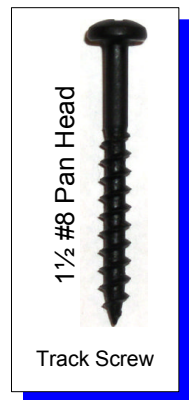
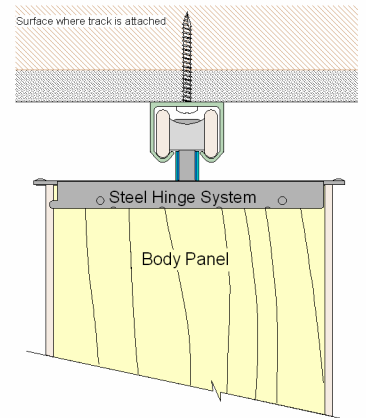

Stack the door to one end of the track (either side of the opening is OK) and attach the other end of the track to the header. Use 1 1/2" #8 pan head screws through the first 2 holes at the end of the track. Seat the head of the screw firmly against the track.

If the screws didn't go into a solid part of the header (soft stuff like sheet rock or acoustical tile doesn't count) at least 3/4", now would be a good time to go to the hardware store and get longer #8 Pan Head or Truss Head screws.



Transfer the door to the attached end of the track. Finish attaching the track with 1 1/2" #8 Pan Head screws.



**Check it out!** Move the door back and forth along the track looking for smooth operation. Most frequent problems include screw heads sticking out, wheels sideways or debris in the track.



### ***If the track is in***

### ***two or more pieces***

Find the longest piece of track. If they are all the same size, just pick one, any one.

Insert the alignment pins into the groove of the track at the end that will mate to the next section. The split in the pin **MUST BE AWAY** from the slot in the track. Drive the spring pins completely into one track using a hammer.

Use 1 1/2" #8 Pan head screws to attach the track to the header. Start at the jamb side where the door will stack and put in enough screws to accommodate the stacked door. Seat the head of the screws firmly against the track.

If the screws didn't go into a solid part of the header (soft stuff like sheet rock or acoustical tile doesn't count) at least 3/4", now would be a good time to go to the hardware store and get longer #8 Pan Head or Truss Head screws.

### **Pin Split**

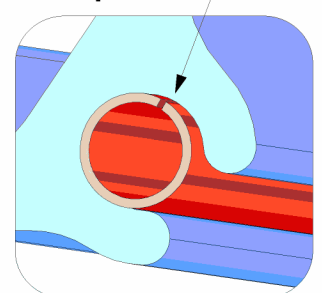

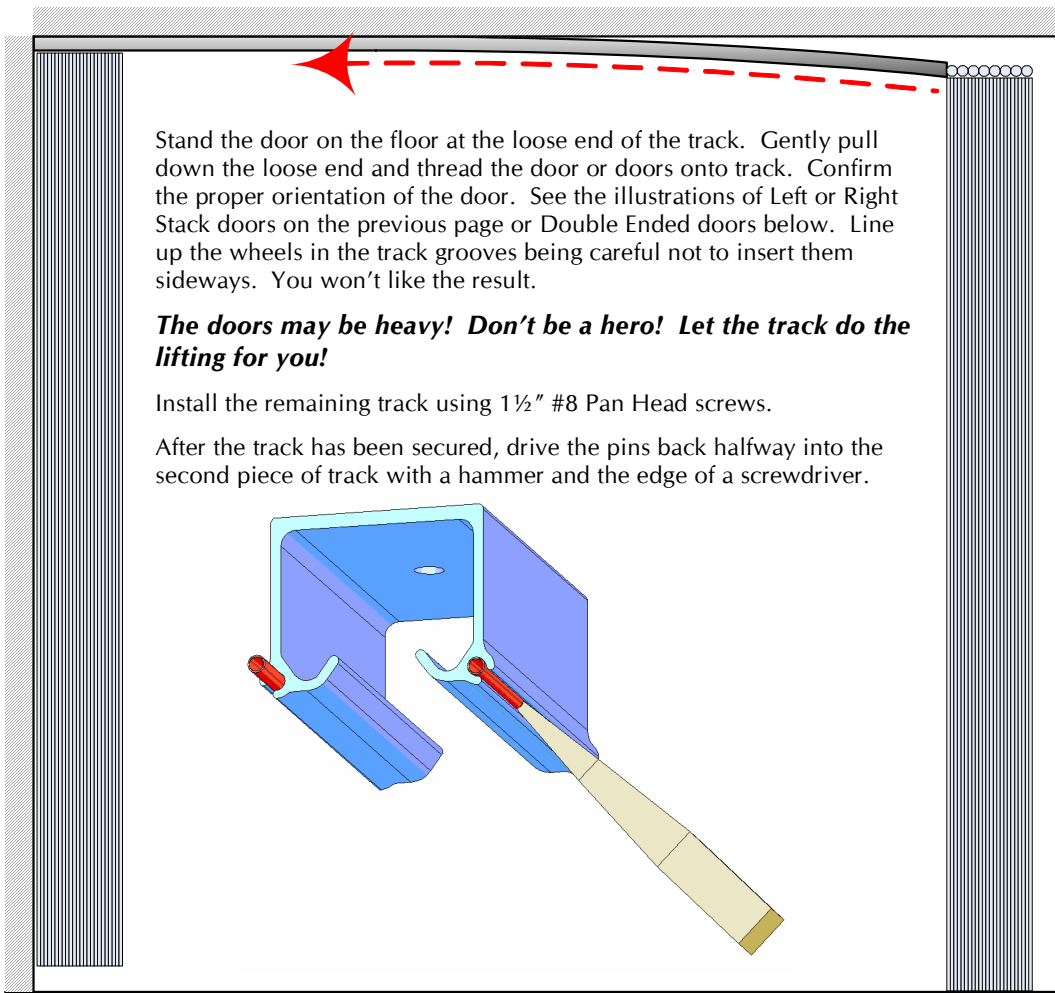
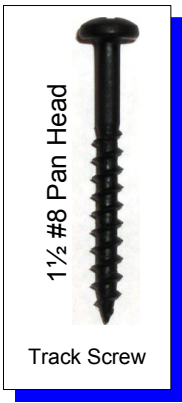

Stand the door on the floor at the loose end of the track. Gently pull down the loose end and thread the door or doors onto track. Confirm the proper orientation of the door. See the illustrations of Left or Right Stack doors on the previous page or Double Ended doors below. Line up the wheels in the track grooves being careful not to insert them sideways. You won't like the result.

***The doors may be heavy! Don't be a hero! Let the track do the lifting for you!***

Install the remaining track using 1 1/2" #8 Pan Head screws.

After the track has been secured, drive the pins back halfway into the second piece of track with a hammer and the edge of a screwdriver.

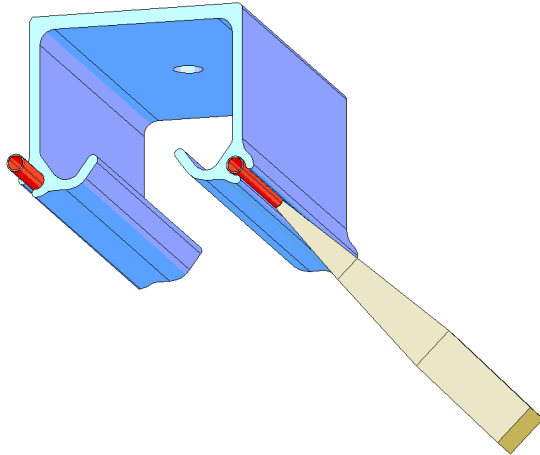

This next section is the most critical. Improperly installing the Mounting Panel results in the majority of trouble calls to Woodfold.

Repeat after me: **I will read this section. I will read this section.**

**3. Mounting Panel**

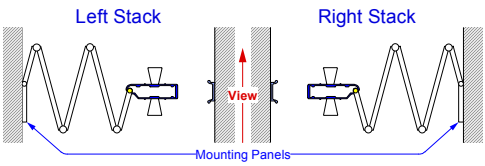

If your door has a mounting panel like one of those to the left, you need to read this Section.

If your door looks like the picture to the right, it is a double-ended door and you may skip ahead to Section 4.

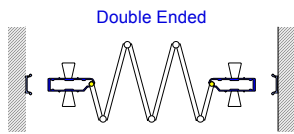

Push the door to the side that will be fastened permanently to the wall. Let the door form its own plumb (hang free) and carefully mark the wall with a pencil at the edge of the mounting panel near the top and bottom of the door.

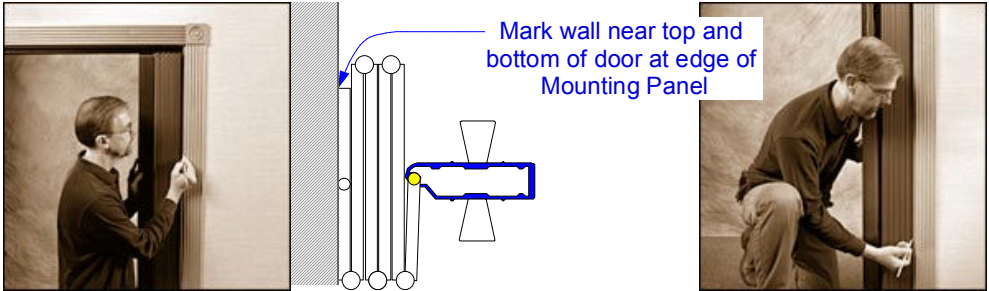

**It is important! Make the marks while the door is in its stacked position or the door will not close properly.**

OK! Here comes the critical step. You just marked the wall at the top and bottom of the mounting panel edge with the door stacked. Now, extend the door to have access to the Mounting Panel. Hold the Mounting Panel edge at the pencil marks at both top and bottom!

**Caution! Take care when attaching the Mounting Panel to the wall. As you unfold the door to insert the screws, the position of the Mounting Panel may move away from your marks. Trust your marks! Sometimes, the marks look "off" when the door is extended.**

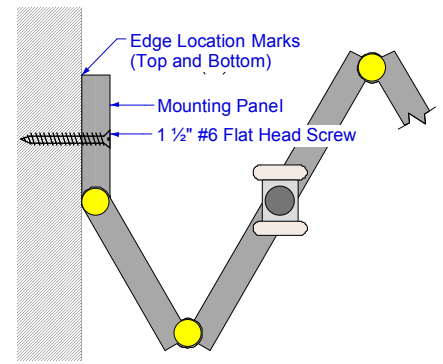

Insert 1 1/2" #6 flat head screws about 8" up from the floor and 8" down from the track.



**Check it out!** Can you see the pencil marks? If not, the door has shifted. If there is a gap between the edge and your marks, the door has shifted the other way. Stack the door against the Mounting Panel; it should form a neat, tight stack. DON'T Force it. If it binds, you missed your marks!

When the door stacks properly, re-extend it and install 2 more screws between the first 2, about equal distances apart.

#### 4 Interlocking Jamb Molding

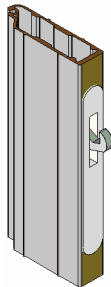

##### Hook style catch

Dry fit the Interlocking Jamb Molding against the wall, directly under the track. It should fit snugly against the wall and the track at the top.

If it needs to be trimmed, trim it at the bottom. The arrow sticker on the back pointing up can easily determine top and bottom.

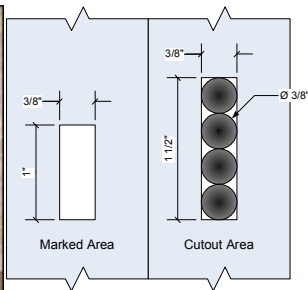

Trace the 3/8" x 1" slot in the Interlocking Jamb Molding onto the wall. Remove the Interlocking Jam Molding and add 1/2" to the top of the tracing.

Drill a series of 1/2" deep holes within the marked area with a 3/8" bit. Clean out the waste with a sharp chisel.

Attach the interlocking jamb molding with 1 1/2" #6 Flat head screws, through the pre-drilled holes and into the wall behind.

##### Magnetic Latch

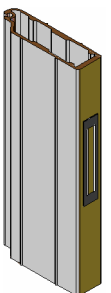

Dry fit the Interlocking Jamb Molding against the wall, directly under the track. It should fit snugly against the wall and the track at the top. Each jamb molding is pre-cut to fit the opening, however, trim the molding with a hacksaw if needed.

Attach the Interlocking Jamb Molding to the wall with 1 1/2" #6 Flat head screws.

Center the Strike Plate on the magnet with the adhesive side out. Remove the protective tape from the adhesive backing and push the door firmly shut.

When you re-open the door, the strike plate should stay temporarily stuck in position. Drill through the center of each strike plate screw hole and Interlocking Jamb Molding using a 5/32" drill bit. Screw down the strike plate using 1 1/2" #6 Flat head screws.

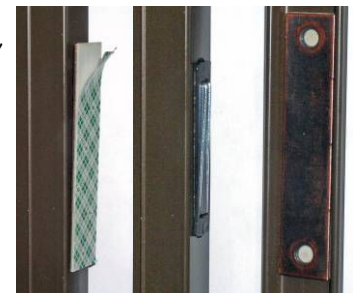

**Check it out!** Open and close the door a few times then step back and admire your work.

**Installation is complete!**

**Thank you for purchasing a Woodfold door.**