

FOLDING DOORS  
**Panelfold® Scale/4®**

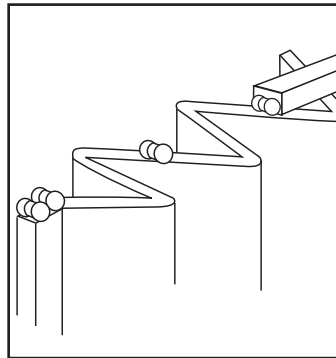

**PRODUCT BRIEF**



**FEATURES.**  
**Scale/4®** wood folding doors, with 4" (102) wide, 3/8" (10) thick laminated, high density engineered wood core panels, the practical alternative for saving space with a great look. The wide variety of surfaces, the narrow profile and proven performance make Scale/4 doors the natural choice. Scale/4 doors also feature dual walled Memory Action® vinyl hinges, aluminum track, double nylon wheels, Touch-Bar™ positive latches and

jamb mould and manual operation. Heights to 8'1" (2464).

**PANEL FINISHES.** A full range of panel surfaces are regularly available including vinyl, wood veneers, and high pressure plastic laminates. Color selectors are available.

**TYPES OF APPLICATIONS**  
 See pages 2 & 3 for details.

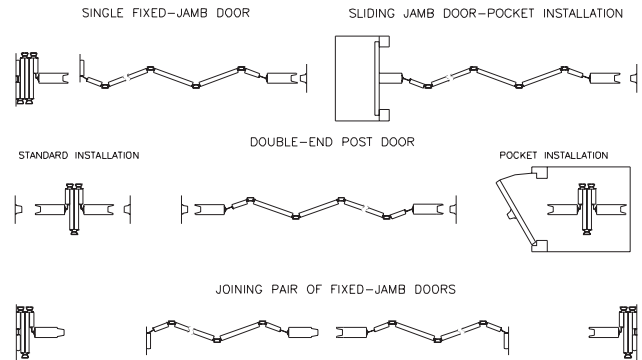

**ELEVATIONS**

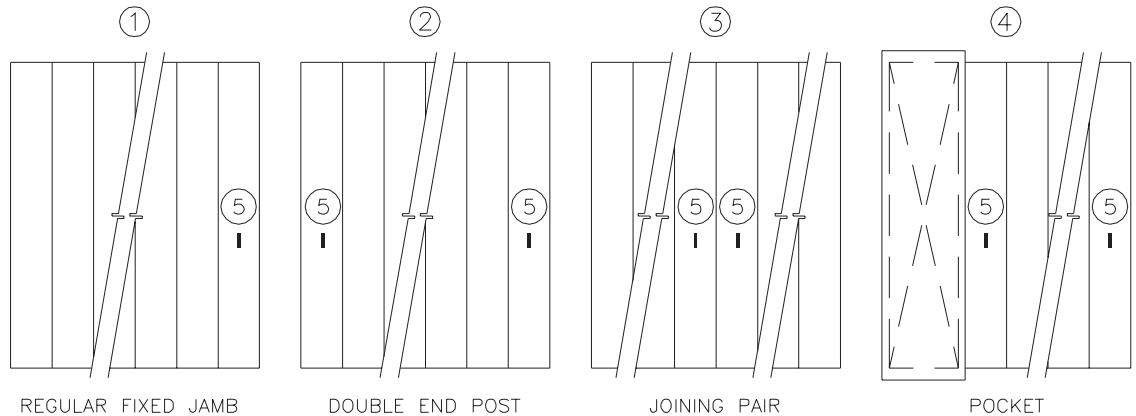

**APPLICATIONS DESCRIPTIONS**  
 See page 4 for Product Specifications

- ① REGULAR FIXED-JAMB doors may be permanently attached at either jamb for single openings. If security features are to be used, either right-hand or left-hand stack should be specified with the security type (cylinder, privacy turn or emergency release) to be installed on the face or reverse side of the door indicated on the drawings.
- ② DOUBLE END POST doors may be latched at both jambs and may be stacked at either end of the opening. Double End Post doors may be used for single openings; joining pairs; or for multiple units in one opening. Double End Post doors can be pocket recessed and must be specified if curved switches are installed.
- ③ JOINING PAIR OF FIXED-JAMB doors may be permanently attached at both jambs for single openings.
- ④ POCKET RECESSED doors may be supplied with a Double End Post or a Sliding Jamb for single openings or for joining pairs of doors.
- ⑤ SECURITY FEATURES may be installed to prevent opening of the doors with keyed cylinders (standard or optionally master-keyed), privacy turns or emergency (coin-slot) releases.



# Scale/4® Folding Doors

## APPLICATIONS DETAILS

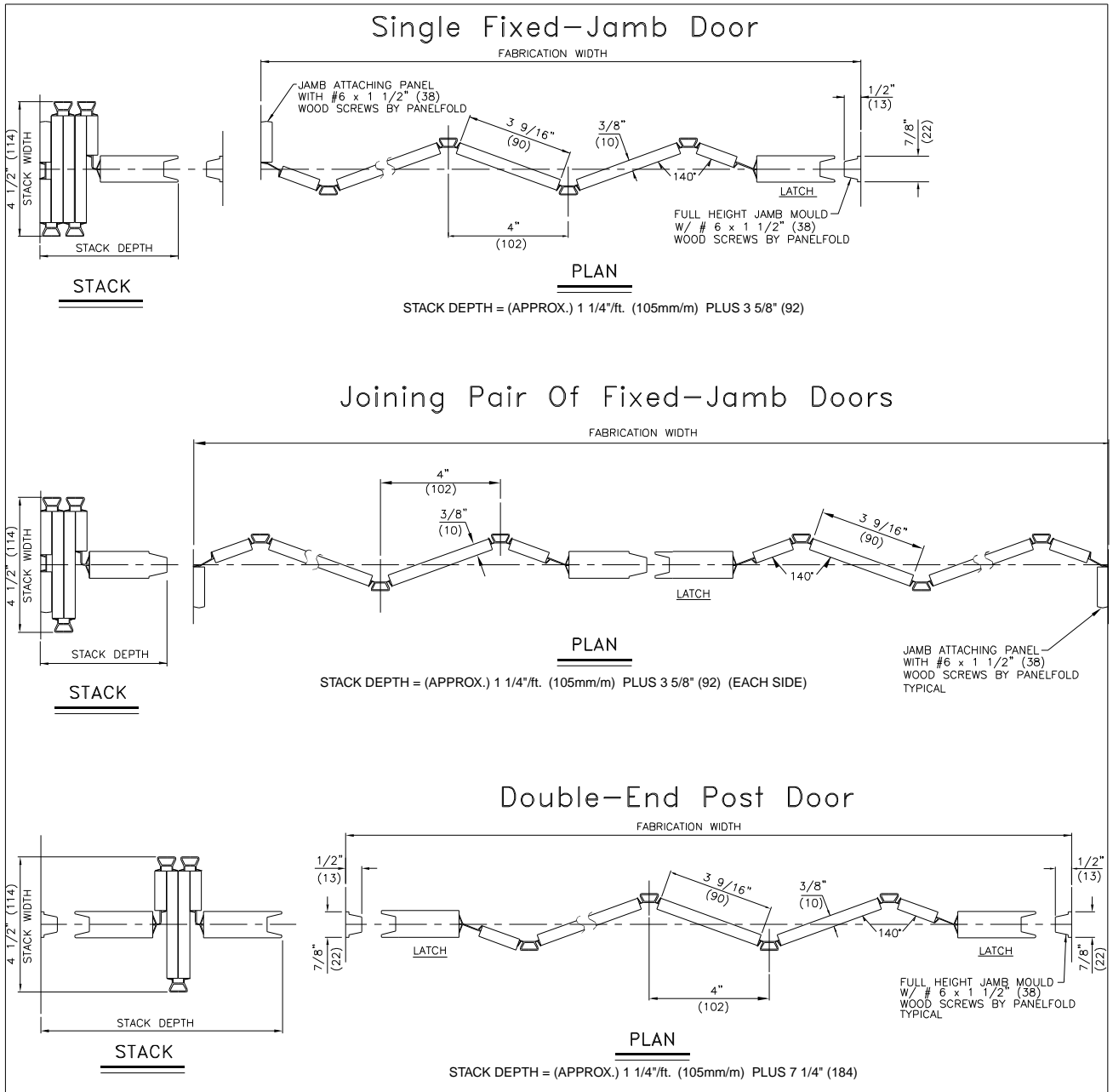

All dimensions shown in parentheses are millimeters. Scale: N.T.S.



# Scale/4® Folding Doors

## APPLICATIONS DETAILS

### Double End Post Door—Pocket Installation

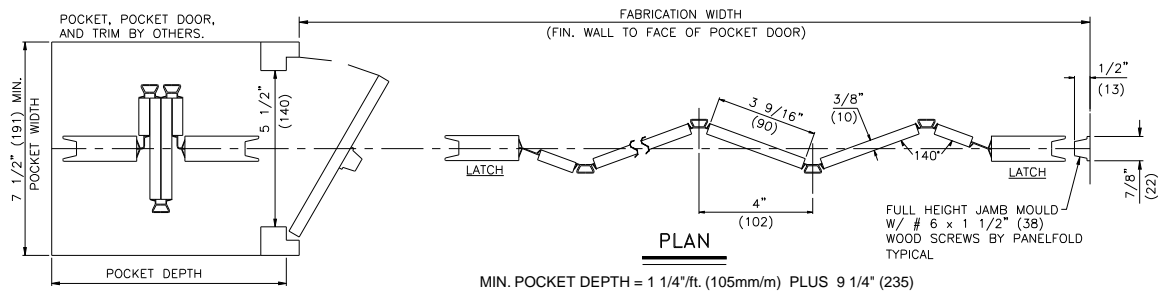

### Sliding Jamb Door—Pocket Installation

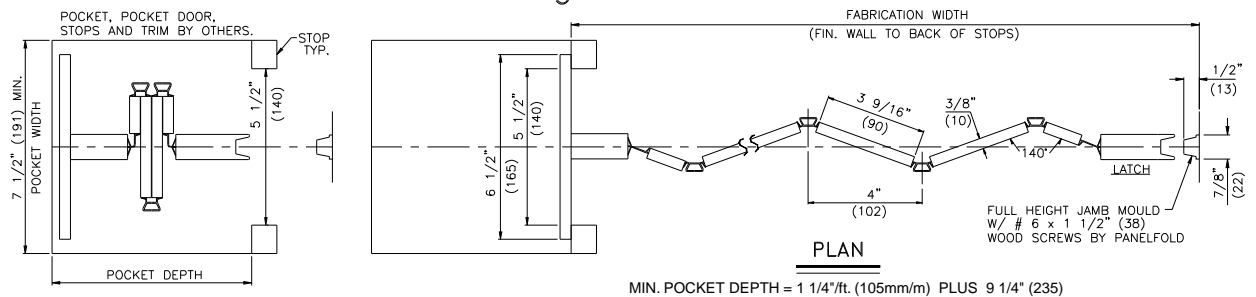

## VERTICAL SECTION—HEAD DETAILS

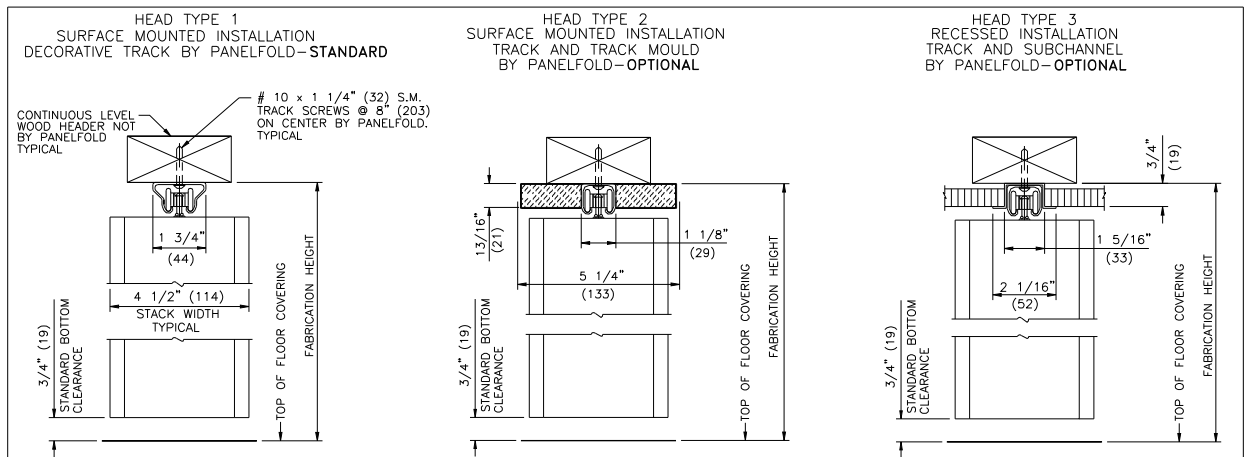

All dimensions shown in parentheses are millimeters. Scale: N.T.S.

## Scale/4®

### PRODUCT SPECIFICATIONS: SECTION 08350 - FOLDING DOORS

#### PART 1 GENERAL

(See Project Guide Specifications for Scope, Related Work, References, Submittals, Product Delivery and Acceptable Manufacturers paragraphs.)

#### PART 2 PRODUCTS

- 2.1 FOLDING DOORS** shall be manually operated wood, folding type as manufactured by Panelfold, Inc., Miami, Florida, U.S.A. and installed by an authorized representative of the manufacturer in openings prepared by others to Scale/4 requirements.
- 2.2 TRACK AND HANGERS:** Track shall be extruded aluminum. Hanger assemblies with two nylon wheels shall be suspended on alternate panels. A four-wheel truck hanger assembly shall be installed on each end post.
- 2.3 PANEL SURFACES:** Panels shall be specially laminated engineered wood core, bonded with water-resistant, plastic glue and surfaced with one of the following (colors to be selected from manufacturer's standards):
- 2.3.1 Woodtex® wood grain vinyl, Class A flame spread.
- 2.3.2 Startex™ solid color vinyl, Class A flame spread.
- 2.3.3 Fabrictex® fabric textured vinyl, Class A flame spread.
- 2.3.4 Ropetex® rope textured vinyl, Class A flame spread.
- 2.3.5 Genuine wood veneer shall be (specify: clear lacquer finished; unfinished, sanded ready for field finishing by others; factory specially finished to match owner's submitted sample) species as specified: White Ash; Red Oak; Natural Birch; White Maple; or American Walnut.
- 2.3.6 High pressure plastic laminate, vertical grade.

**2.4 CONNECTOR HINGES:** Panels shall be hinged and edge sealed against sound light and air transmission with heavy duty, dual-wall, flame resistant, extruded vinyl. Hinges shall be securely locked into and protect the panel edges. They shall provide "Memory-Action" causing the panels to extend and stack equally, smoothly, and quietly. Color from manufacturer's selector.

**2.5 TRIM:** Doors shall be supplied with (specify: decorative track; optional plain track with track mould to conceal track; or optional plain track with extruded aluminum sub-channel for recessed track). A jamb mould for jamb closure shall be furnished.

**2.6 HARDWARE:** Handles, Touch-Bar automatic latches, all necessary screws, installation hardware and instructions shall be furnished. Security units shall be as specified: Privacy latch and emergency release; cylinder lock one side only; cylinder lock one side, privacy lock other; cylinder lock two sides. Optional. Master-keyed insert type cylinder with lazy cam and flat tail piece, by others, shall be installed in lieu of regularly furnished cylinder.

**2.7 STACK FORMULA:** Approximately 1-1/4"/ft. (105mm/m) plus 3" (76mm) for each end post assembly.

**2.8 HANGING WEIGHT:** Approximately 1.7 lbs./ft.<sup>2</sup> (8kg/m<sup>2</sup>).

#### PART 3 EXECUTION

(See Project Specifications Guide for Execution, Inspection, Preparation, Installation, Cleaning and Demonstration paragraphs.)

**NOTE:** The ASTM - 84 procedure Class A flame spread and other test results referenced herein are for comparison purposes only and are not intended to reflect hazards presented by this or any other materials under actual fire conditions.

For further information, or additional technical information, contact your Panelfold distributor.

**Panelfold®**

FOLDING DOORS • ACOUSTICAL FOLDING PARTITIONS  
OPERABLE WALLS • RELOCATABLE WALLS